

LINEAR WIDEBAND POWER AMPLIFIER

Model – MB5.55.7G444512

General Description:

Elite RF's MB Series amplifier is a wideband power amplifier designed for CW signals fabricated on GaN on SiC process and can operate up to **5.7 GHz**. These amplifiers offer high power density, decade bandwidth performance, low thermal resistance, and wideband performance. They can be widely used for military and commercial applications. **Like all Elite RF amplifiers**, this product comes with an industry leading warranty.



Features

Wide Freq. Range
High Output Power
High Gain
High Reverse Isolation
Built-in Protection
Enable/Disable input (ground to disable)

Indicator options

DC Power
Temp Fault

Protections

Thermal Overload
Over Voltage
Reverse Polarity

ELECTRICAL SPECIFICATIONS

Parameter	Symbol	Min	Typ	Max	Unit
Frequency Range	BW	5500		5700	MHz
Output Power CW	Psat		30		Watt
Output Power at 1 dB Compression	P1dB		20		Watt
Small Signal Gain	Gp		47		dB
Gain Flatness	Delta Gp 1		+/- 2		dB
Input VSWR	S11		2:1		Ratio
IMD @ 1 watt/tone @ 1 MHz spacing	IP3		48		dBm
Harmonics	H		-20		dBc
Spurious Signals	Spur		-60		dBc
Operating Voltage	VDC	11.5	12	12.5	VDC
Current at 20 watts	Current		5		Amps
Class of Operation	C		AB		Class
Noise Figure	NF		5		dB
Large Signal Gain	Lsg		45		dB
Max Load VSWR @ 20 Watts	ML		6:1		Ratio

ENVIRONMENTAL CHARACTERISTICS

Parameter	Symbol	Min	Typ	Max	Unit
Operating Case Temperature	Tc	-20		+60	Deg. C
Storage Temperature	Tstg	-40		+85	Deg. C
Relative Humidity (non-condensing)	RH			95	%
Altitude	ALT			10,000	Feet
Vibration/Shock	VI /SH				Normal Truck Transport

MECHANICAL CHARACTERISTICS

Parameter	Symbol	Min	Typ	Max	Unit
Dimensions	Dim		7.5 x 4.0 x 1.0		Inches
Weight	Wt.		1		lbs.
Connectors In/Out	RF Conn		SMA/SMA		-
Cooling	Th		Heat sink required		-

OPTIONS

Parameter	Add suffix to part number
Heat sink and fans	- H
Isolator with forward and reverse voltage outputs	N/A
TTL Input Trigger	- T

Mechanical Drawings

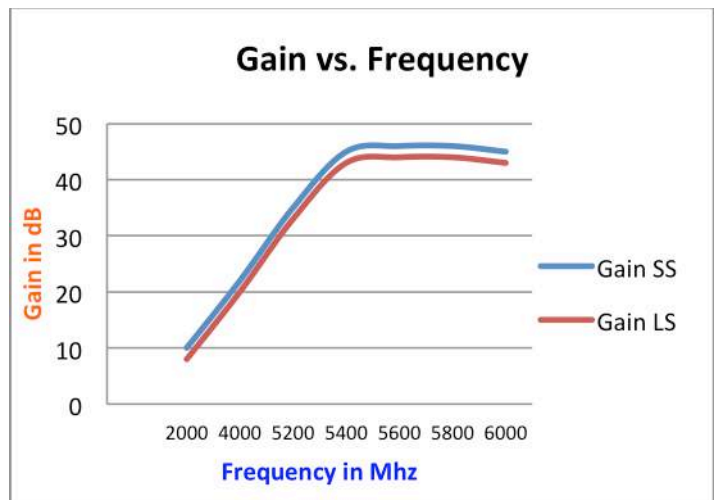
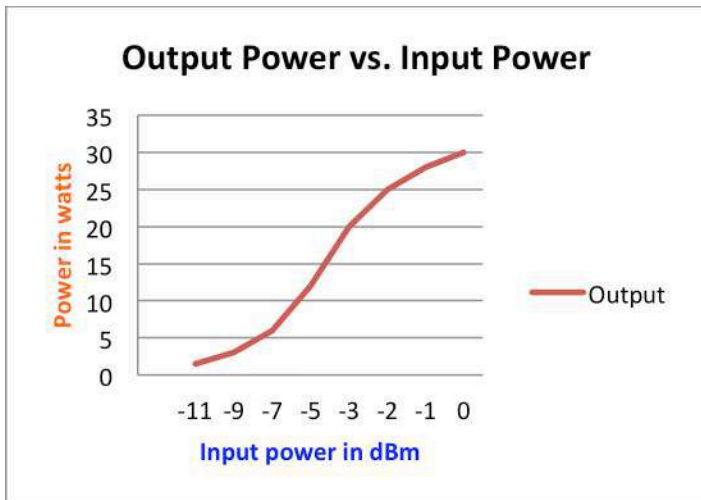
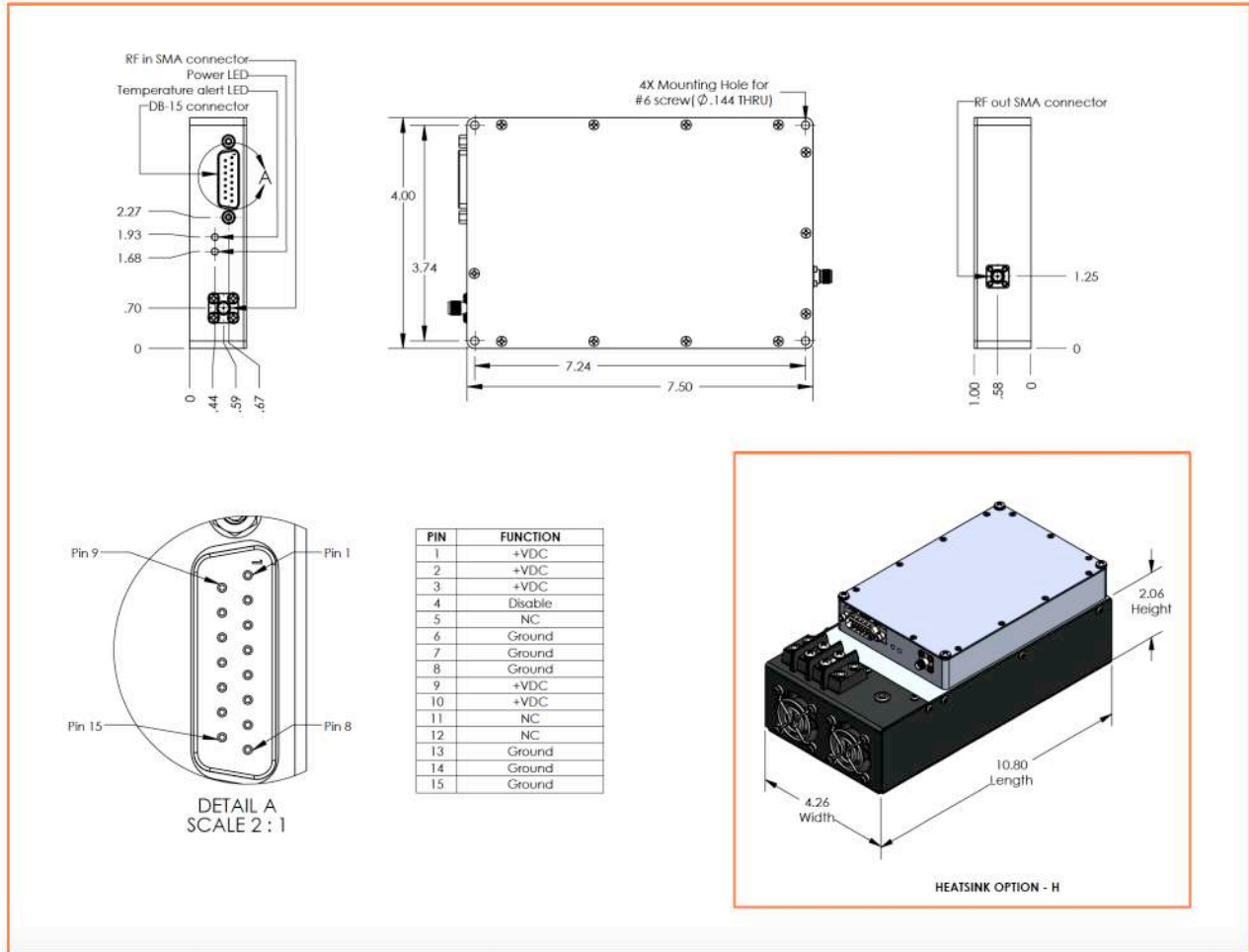

Elite RF LLC

1700 Tower Dr, Hanover Park, IL 60133, USA
Call us for customer service/technical support at: 847-592-6350
Email: sales@eliterf.com Web: www.eliterfllc.com

Rev 3 08/23/2023:
Specifications subject to change, consult sales for latest information